

Fuzzy Logic Controller Based Efficiency Power Management of Grid Operated Microgrid

**B. Phani Ranga Raja¹, A.Chinni Krishna^{*2}, M.Pavani^{*3},
V.Naga Ramesh^{*4}, V.Leela Sai Sathvik^{*5}**

¹Assistant Professor, Department of Electrical and Electronics Engineering Usha Rama College of Engineering and Technology, Telaprolu, India.

^{2,3,4,5}Student, Department of Electrical and Electronics Engineering Usha Rama College of Engineering and Technology, Telaprolu, India.

Abstract

The exponential increase in electrical energy demand in the current scenario makes the world to turn towards the use of renewable energy sources naturally. The best way to utilize the renewable energy sources is in the form of microgrid. Microgrids are having multiple distributed energy sources and energy storage elements located nearer to the consumer. This paper implements a Fuzzy Logic Controller that efficiently manages the loads in a grid operated Microgrid. In this paper, maximum power point tracking (MPPT) with fuzzy logic controller is used for a grid operated microgrid constituted by solar system and battery. The system consists of Photo Voltaic (PV) system with MPPT controller, Battery with Buck boost converter, Inverter, critical and non-critical loads and utility grid. The simulation results prove that the efficiency of the fuzzy logic controller for different irradiation level with different load conditions has been improved.

Keywords: Fuzzy logic controller (FLC); PV system; Battery.

Introduction

The evolution of micro grid starts in the view that the power loss during the transmission can be greatly reduced, the maximum utilization of renewable energy sources can be achieved, reliable power to the consumers, pollution free environment etc. The MicroGrid (MG) is defined as the collection of various renewable energy sources such as solar, wind turbine, fuel cell etc, energy storage elements and loads. The conventional power sources can also be included in the MicroGrid. The units of the microgrid (MG) are commonly located near to the consumer so as to meet the main objectives of the micro grid. The microgrid operation may be considered as the autonomous mode of operation.

In Autonomous mode, the system should be stable concerning the voltage and frequency. In grid connected mode, the cost of power supplied to the utility grid should be minimum and also the voltage in the micro grid must be optimum. The effective use of micro grid put down in the proper selection of the size and location of the distributed generation (DG) sources. Many algorithms have been proposed for the optimal location and rating of the DG's, capacitors in the recent days.

The MPPT based fuzzy logic control for stand-alone solar system has been proposed in. For various weather conditions, the fuzzy controller results are compared with the perturbation and observation algorithm and the results prove that the proposed algorithm gives the better response in terms of tracking performance. Even the fuzzy logic controller is used for speed control of an induction motor. The controller has the ability to track the speed of the induction motor in closed loop scenario. A fuzzy based control algorithm for analyzing the charging and discharging level of the battery used in hybrid wind and solar power system for stand-alone applications has been implemented in. The SOC (State of Charge) of the battery is controlled using the fuzzy logic controller and compared with the conventional PI (proportional Integral) controller and results prove that the fuzzy control maintains the SOC level of the battery in the anticipated level for the long life of the battery. The fuzzy logic controller finds its application in the field of chemical process also. The liquid level and pH parameter can be maintained at desired level by the FLC. The authors proposed several algorithms for the approximating model of interacting level and pH process. The results from FLC are compared with other control techniques like PI, Model predictive control (MPC) and PISPW (Proportional Integral Set point weighting).

The paper is organized as: Section 1 briefs the introduction about the micro grid, related literature work discussion; Section 2 discusses the block diagram and the components in the system; Modeling of the PV panel is given in section 3. Section 4 explains the concept of fuzzy logic controller with the membership functions and rules; Simulation results are elaborated in the section 5. Conclusion is offered in section 6.

• **Block diagram of the Proposed system**

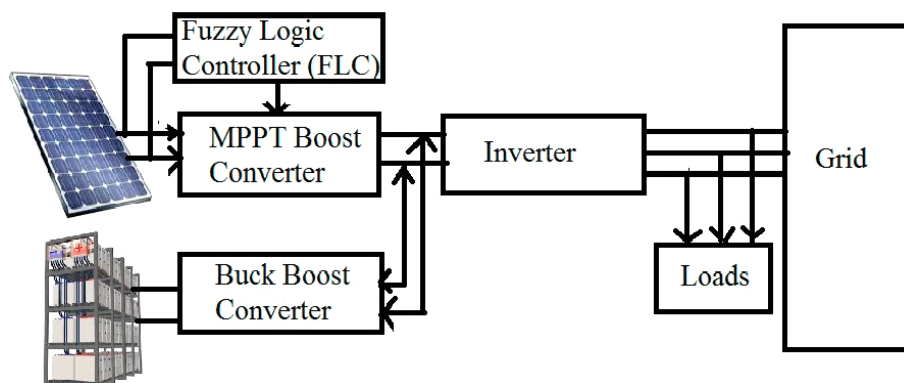

Figure 1. Block diagram of the system

The grid operated microgrid in Figure 1 consists of solar panel with MPPT control using Fuzzy logic controller (FLC), battery with buck-boost converter, Grid tied inverter and the critical and non-critical loads. Because of the nonlinear relation between the irradiation, temperature and the resistance of the solar cell, the output efficiency is also nonlinear in nature. In order to extract the maximum power from the solar cell, maximum power point tracking (MPPT) is applied. For any load and weather conditions, the MPPT must be able to maximize the power output from the solar. In order to meet the load demand of the critical loads connected in the system, it is necessary to get consistent power from the source. This can be implemented with the help of the fuzzy logic controller (FLC) proposed in the system. Many papers have proposed the fuzzy logic controller mostly for stand-alone applications. This paper proposes

a Fuzzy logic controller for the Grid connected solar system using Fuzzy logic controller with battery backup controlled by buck boost converter.

• **Modeling of PV Cell**

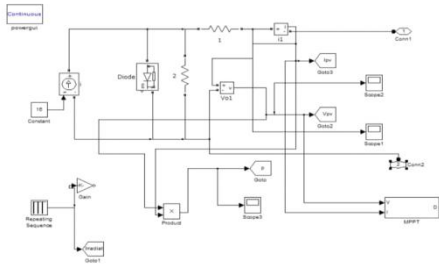

Figure 2. Equivalent Circuit of a solar cell

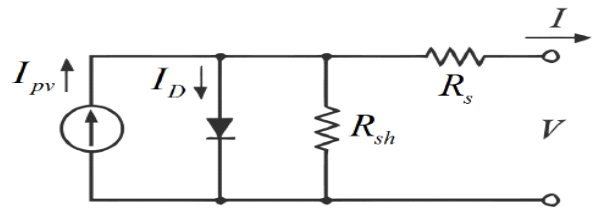

Figure 3. Simulation circuit of a solar cell

The equivalent circuit of the solar cell is shown in Figure 2. The current source is connected in parallel with a diode. The series resistance R_s and shunt resistance R_{sh} has the values of almost zero and infinity in ideal condition. The current from the diode can be represented by the equation (1)

$$I_{pv} = I_{ph} - [I_D + I_{pv} R_{se} + V_{pv}] / R_{sh}$$

where I_d = diode current (A);

V_d = diode voltage (V);

I_{sat} = diode saturation current (A);

V_T = temperature voltage = $k \cdot T / q \cdot Q_d \cdot N_{cell} \cdot N_{ser}$;

T = cell temperature (K);

k = Boltzman constant = 1.4806×10^{-23} J/K; q = electron charge = 1.7022×10^{-19} C;

Q_d = diode quality factor;

N_{cell} = number of series-connected cells per module; N_{ser} = number of series-connected modules per string;

The Simulink diagram for the solar cell is given in Figure 3. The power output from the solar panel is 84kW. The maximum power from the cell depends on the current and voltage. These factors also depend on the solar insolation and temperature. In spite of the varying climatic conditions, the solar output power should be constant for maintaining the voltage across the load constant. The irradiation is being considered as 1000 W/m^2 and 850 W/m^2 for validating the results.

Fuzzy Logic Controller (FLC)

Fuzzy logic is popularly used now a day for controlling various parameters in the system. In the Microgrid, FLC find its application for controlling the peak point in the MPPT. Fuzzy logic includes three basic function blocks such as Fuzzification block, Inference Engine and Defuzzification block. In the fuzzification block, all the real physical

variables are changed in to fuzzy variables called linguistic variables. Here the voltage and the current from the solarpanel is used for determining the power. The MPPT control is used for finding the change in the duty ratio of the DC-DC converter by considering the slope of the P-I characteristics of the solar cell. The slope is considered as the error E and change in the error (CE) is also taken as input variables to the Inference engine [9]. The input variables are converted to the fuzzy variables as NB (Negative Big), (NS) Negative Small, (Z) Zero, (PS) Positive Small, PB (Positive Big) using the fuzzy subset.

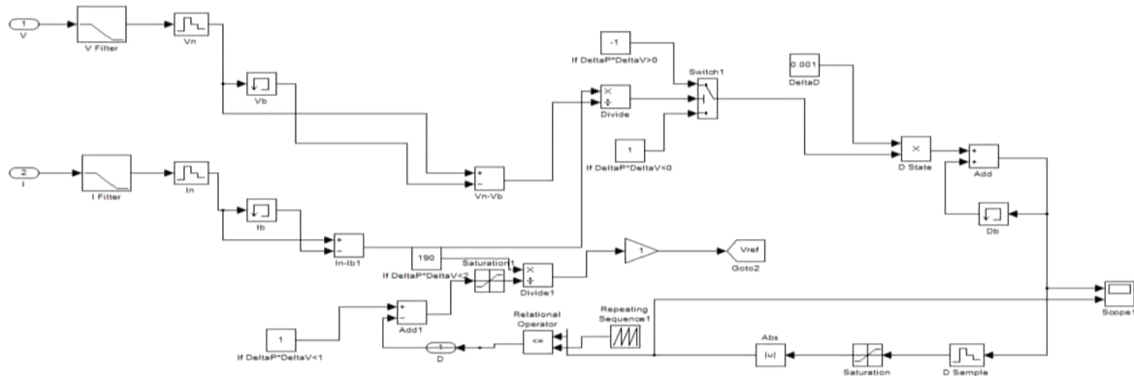

Figure 4 .Simulation circuit of the controller subsystem

The Figure 4 shows the simulation circuit for the Maximum power point tracking subsystem used in the controller. The Fuzzy Inference System (FIS) takes the input and apply the fuzzy rules to make the fuzzy outputs.

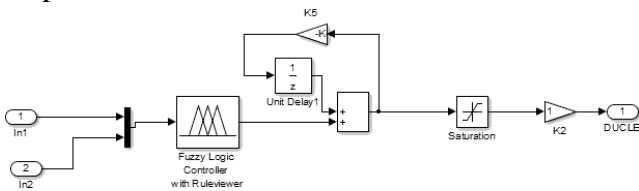

Figure 5. Fuzzy logic controller with rule viewer simulation circuit

Table 1.Fuzzy Control rules

<i>CE</i>					
<i>E</i>	NB	NS	Z	PS	PB
NB	NB	NB	NS	NS	Z
NS	NB	NS	NS	Z	PS
Z	NS	NS	Z	PS	PS
PS	NS	Z	PS	PS	NB
PB	Z	PS	PS	PB	PB

The membership functions for the inputs and output are shown in Figure 6. The fuzzy rules are created and given in Table 1. The operating point at which the power output is maximum can be adjusted by adjusting the duty ratio. The proposed fuzzy rules give the maximum operating point and the constant voltage output at grid side.

5.Simulation results

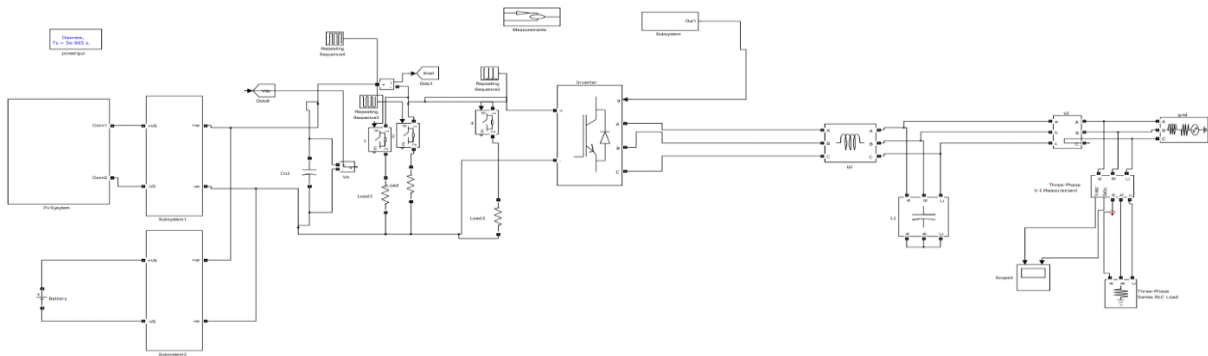

Figure 7. Simulation circuit for the Grid connected Micro grid

The Figure 7 shows the simulation circuit for the grid connected micro grid in MATLAB/Simulink. Fuzzy logic toolbox is used to implement the fuzzy logic controller (FLC). The loads considered as critical and non-critical loads. The constant DC voltage from the solar panel is synchronized with the battery voltage and it is given to the inverter. The inverter converts the fixed DC into AC supply for supplied to the grid. The simulation is carried out for $1000\text{W}/\text{m}^2$ and $850\text{W}/\text{m}^2$ irradiation level in offline condition .After running the simulation, the results, and the Fuzzy controller has the ability to maintain the constant voltage at the grid level.

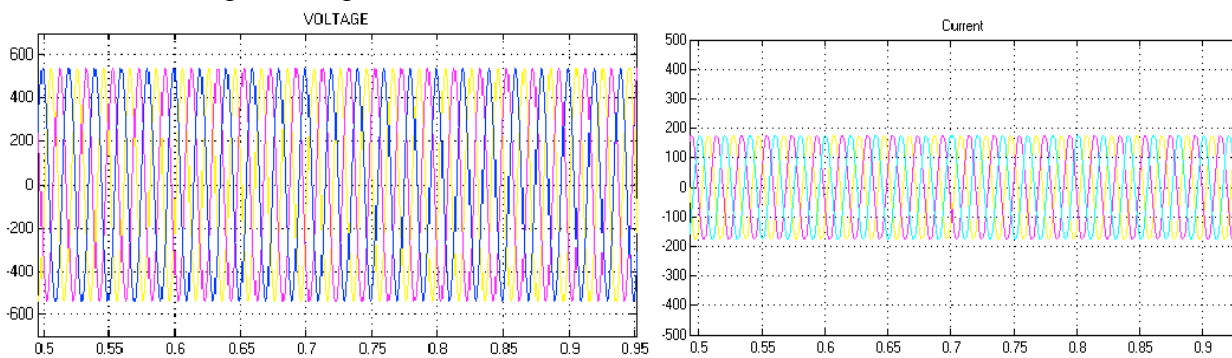

Figure 8. Grid voltage and grid current at $1000\text{W}/\text{m}^2$ irradiation level

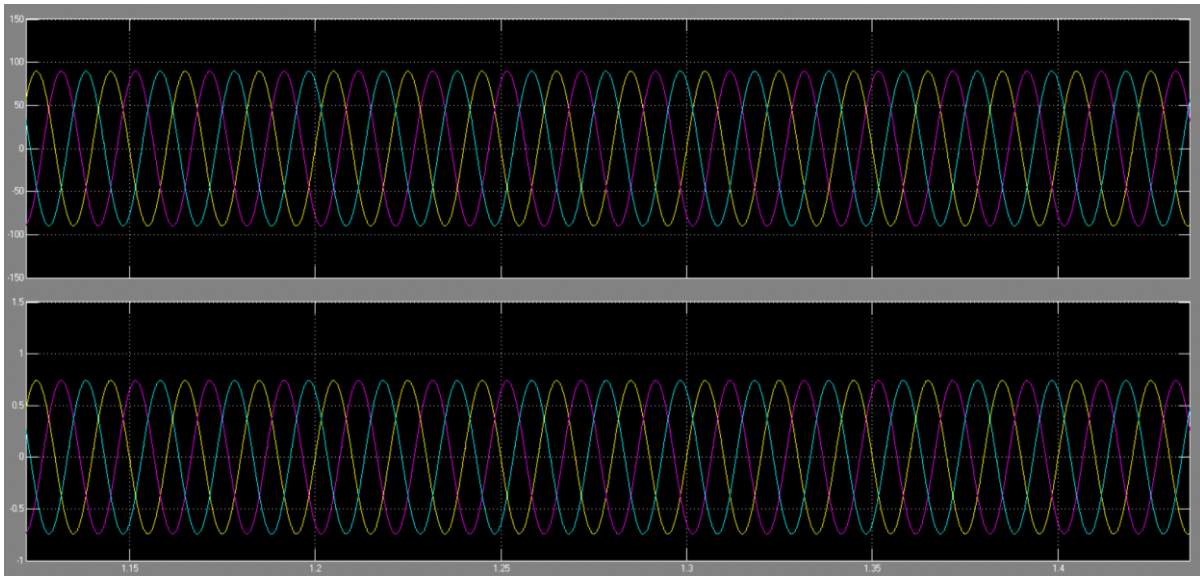

Fig 9. Grid Voltage and Grid Current at AC Loads

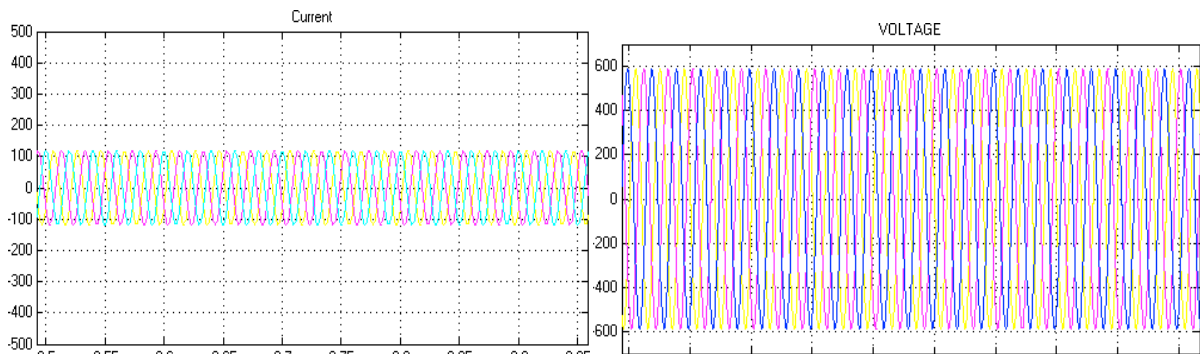

Figure 10. Grid voltage and grid current at 800W/m^2 irradiation level

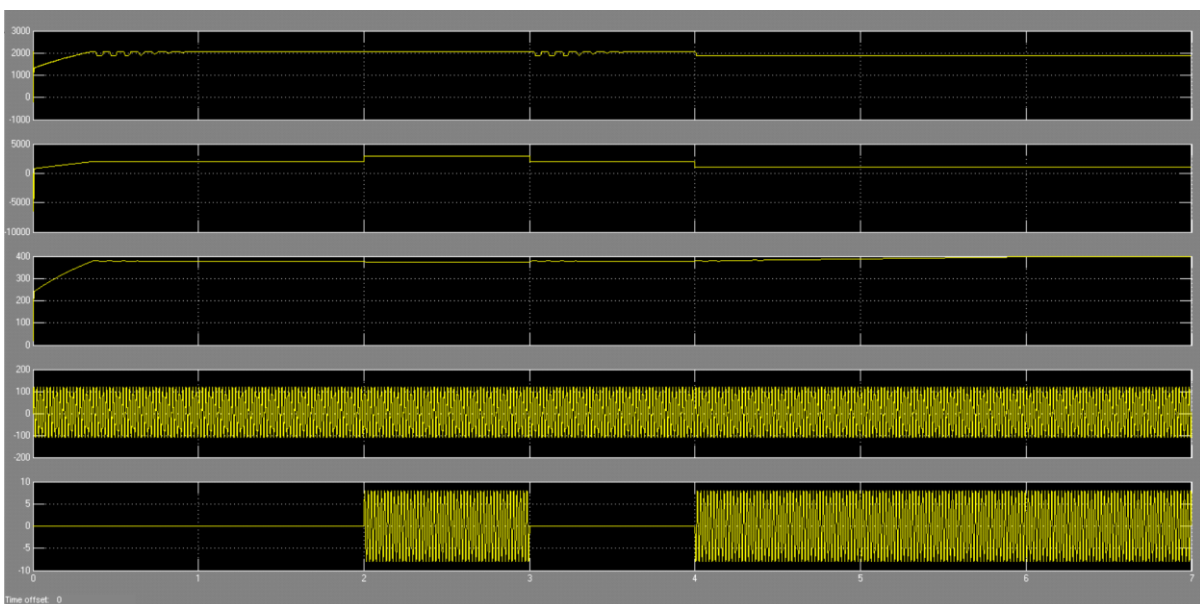

Fig 11. Solar Power, Current, Voltage and Overall Grid Voltage and Grid Current Wavwform

The Figure 8 and 10 shows the grid voltage and current for irradiation level of 1000 W/m^2 and 800 W/m^2 respectively. From the figure, it is proved that the voltage at the grid is maintained at constant level throughout the simulation period. The simulation is carried out for 1 second. The rule viewer diagram and the surface viewer are shown in the Figure 1.

Conclusion

In the paper, a DC microgrid with hybrid storage system is investigated. A power management strategy for this DC microgrid is proposed, in which the bus voltage is employed as a carrier to represent different operating modes. The hybrid energy storage system in this microgrid that contains two complementary type storage elements---battery and super-capacitor, can enhance the reliability and flexibility of the system based on their special supply logical. Different from the previous studies, the AC grid has a new supply status in the system. The practical feasibility and the effectiveness of the proposed control strategies have been validated by the simulation of MATLAB model.

References

1. Lasseter, R.H. "Microgrids," Power Engineering Society Winter Meeting, New York, Vol.1, Jan.2002, pp:305-308.
2. Estefanía Planas, Jon Andreu, José Ignacio Gárate, Iñigo Martínez de Alegría, Edorta Ibarra. "AC and DC technology in microgrids: A review," Renewable and Sustainable Energy Reviews, Vol 43, Mar. 2015, pp:726-749
3. Gianfranco Chicco, Pierluigi Mancarella. "Distributed multi-generation: A comprehensive view," Renewable and Sustainable Energy Reviews, Vol.13 , Apr.2009, pp:535-551
4. Nanfang Yang, Damien Paire, Fei Gao, Abdellatif Miraoui , Weiguo Liub. "Compensation of droop control using common load condition in DC microgrids to improve voltage regulation and load sharing," International Journal of Electrical Power & Energy Systems, Vol.64, Jan. 2015, pp:752-760,
5. R. Sathish kumar, K. Sathish Kumar, and M. K. Mishra, "Dynamic energy management of micro grids using battery super capacitor combined storage," in Proc. 2012 Annual IEEE India Conference (INDICON), Dec.2012, pp: 1078–1083.
6. Z. Guoju, T. Xisheng, Q. Zhiping, "Research on battery supercapacitor hybrid storage and its application in microgrid," in Proc. 2010 IEEE Power and Energy Engineering Conference, Mar.2010, pp:1–10
7. G. M. Masters, Renewable and Efficient Electric Power Systems, Wiley-IEEE Press, 2004.
8. Sathishkumar R, Sathish Kumar Kollimalla, Mahesh K. Mishra. "Dynamic energy management of micro grids using battery super capacitor combined storage," 2012 Annual IEEE India Conference (INDICON), Dec.2012, PP:1078 – 1083.
9. Xiaolei Hu, K.J.Tseng and M.Srinivasan. "Optimization of Battery Energy Storage System with Super-Capacitor for Renewable Energy Applications," in IEEE 8th International Conference on Power Electronics and ECCE Asia (ICPE & ECCE), May.2011, pp:1552-1557

10. Zhixue Zheng, Xiaoyu Wang, Yongdong Li. "A Control Method for Grid-friendly Photovoltaic Systems with Hybrid Energy Storage Units," in International Conference on Electric Utility Deregulation and Restructuring and Power Technologies, Jul.2011, pp:1437–1440
11. Sathish Kumar Kollimalla, Mahesh Kumar Mishra, Lakshmi Narasamma N. "A New Control Strategy for Interfacing Battery Super-capacitor Storage Systems for PV System," 2014 IEEE Students' Conference on Electrical, Electronics and Computer Science, Mar. 2014, pp:1-6
12. Hicham Fakham, Di Lu, and Bruno Francois. "Power Control Design of a Battery Charger in aHybrid Active PV Generator for Load-Following Applications," IEEE Trans. Ind. Electron, vol.46, no. 1, Jan.2011, pp:85-94
13. Tong Yap, Yingying Tang, Raja Ayyanar. "High Resolution Output Power Estimation of Large-Scale Distributed PV Systems," in Energy Conversion Congress and Exposition (ECCE), Spept.2014, pp:4620-4627.
14. Jiyong Li and Honghua Wang. "A Novel Stand-alone PV Generation System Based on Variable Step Size INC MPPT and SVPWM Control," IEEE 6th International Power Electronics and Motion Control Conference, May.2009, PP:2155-2160
15. Xiao Jianfang, Wang Peng, Leonardy Setyawan. "Hierarchical Control of Hybrid Energy Storage System in DC Microgrids," IEEE Trans. Ind. Electron., Vol 99, Feb.2015, pp:1-10
16. Liu Jiaying, Han Xiaoqing, Wang Lei, Zhang Peng, Wang Jing. "Operation and Control Strategy of DC Microgrid," Power System Technology in Chinese, Vol.38, no.9, 2014, pp:2356-2362
17. Dan Shen, Afshin Izadian. "Sliding Mode Control of A DC Distributed Solar Microgrid," Power and Energy Conference at Illinois (PECI), Feb.2015, PP:1-6.
18. Liu Baoquan, Zhuo Fang, Bao Xianwen. "Control Method of the Transient Compensation Process of a Hybrid Energy Storage System Based on Battery and Ultra-Capacitor in Microgrid," 2012 IEEE International Symposium on Industrial Electronics (ISIE),. May.2012, pp: 1325-1329
19. Huiying Zheng, Shuhui Li, Chuanzhi Zang, Weijian Zheng. "Coordinated Control for Grid Integration of PV Array, Battery Storage, and Super-capacitor," 2013 IEEE Power and Energy Society General Meeting (PES) , July.2013, pp:1-