

DESIGN AND SIMULATION OF A BUCK CONVERTER WITH A DC TO DC PROCESS

K SHRUTI¹, K. ANITHA²

¹M.Tech Scholar, ²Assistant Professor
Department Of Electrical and Electronics Engineering
Tadipatri Engineering College, Tadipatri.

Abstract:

As an improved PQ-primarily based charger for electric powered cars, a BUCK converter with fewer switching factors in keeping with switching cycle is proposed. By the usage of a voltage remarks electricity supply, the proposed PFC BUC converter achieves the first-rate PFC overall performance in DCM mode. As a result, the plate size is reduced. The proposed topology eliminates the unnecessary capacitive coupling loop and useless transport through the internal passive diode bypass formerly hooked up within the BL BUC converter. This significantly improves the charging performance. Improved PQ-primarily based EV batteries, which use a sinusoidal enter voltage with a excessive electricity issue and feature a compelled voltage at a constant price, have been broadly studied inside the literature to cope with these troubles. In the literature on EV batteries, numerous PFC enter converter topologies had been discussed, relying on whether or not they're external or integrated. Various batteries were introduced for electric powered motors, all of which gain from high energy density and efficiency.

Keywords: Battery chargers, Software packages, resonant converters, DC-DC power converters, Mathematical models.

INTRODUCTION

As an stepped forward PQ-primarily based EV charger, a passive-downbridge with a low-conduction switching cycle is proposed. By using a unmarried-output voltage, the proposed PFC buck converter achieves the first-class PFC overall performance in DCM mode. As a result, the plate length is decreased. The proposed topology gets rid of pointless capacitive coupling loops and unnecessary transport thru the inner passive diode pass previously established in the BL buck converter. This extensively improves the coating performance. For lengthy-term growth in nowadays automotive marketplace, battery-electric motors (BEVs) are replacing traditional gasoline-powered motors. A crucial accessory for an electric vehicle is an AC-DC converter based on an outside board or charger, which permits the battery in a BEV (EV) to be charged. Various external and inner-unit topologies of EV battery packs, with either a single- or double-sided configuration, are discussed in the literature under the categories of Course 1, Course 2, or Course three. To optimize strength intake in charging, the outside p.C. Need to have stepped forward strength high-quality (PQ) traits with excessive power density and small form issue. In contrast, a traditional diode bridge rectifier (DBR) EV charger attracts maximum current from the grid, which reduces the enter power thing (PF) and creates a total harmonic distortion (THD) of 55.3 percentage. Table 1 lists the battery rankings and specifications for the EV under evaluation. These waveforms truly show that the output power of the DBR powered plate does no longer comply with worldwide requirements along with the IEC 6100-three-2 well-known.

Advanced PQ-primarily based EV arrays, which use a sinusoidal enter current with a excessive electricity issue and tightly manage the pressured voltage to a consistent fee, have been drastically studied in the literature to deal with those troubles. The literature on EV charging addresses numerous PFC converter topologies, depending on whether or not they depend upon outside or internal charging. Various batteries

were announced for electric vehicles, all of which advantage from excessive electricity density and performance. However, because of the light weight and the potential of cars to be charged at excessive electricity tiers, an outside layout is a extra sensible option. Various PFC converter topologies with alternative enter indicators and zero voltage switching (ZVS) strategies were mentioned. The benefits of switching to a -phase enter include decreased output ripple cutting-edge and decreased inductor size. In addition, when semiconductor devices perform in parallel, conduction losses are minimized. Unlike conventional boost PFC converters, intermediate PFC converters do now not offer the low thermal efficiency of PFC switching. The use of an electric powered vehicle chassis with a resonant LLC converter is being taken into consideration, which has the additional benefits of low electromagnetic interference (EMI) and occasional switching losses. However, the complicated mathematical evaluation of a resonant converter makes it mistaken for an electric powered car over a wide range of input voltages. The best solution for EV chargers is a full-bridge PFC converter [11], but the separate gate driving force association for the 4 semiconductor rods increases the dimensions and complexity. As an end result, diverse unidirectional external PFC EV chargers are taken into consideration to facilitate deployment while preserving the advantages of high energy density and stability. At the enter of those ACs, diverse single-stage and two-degree electricity element correction (PFC) converters generate sizable PQ indices. Several EV topologies for single-degree PFC converters were published in the literature. Due to the low number of parts, the unmarried-disc proved to be powerful for the platform. On the other hand, the presence of a hundred Hz resonant additives inside the output contemporary requires a totally excessive DC coupling capacity. Two-stage rectifiers with PF are a extensively relevant solution in the electrical market for medium electricity applications up to at least one kW. Due to the giant conduction losses caused by the 4 enter diodes, the PFC converter is tormented by the overall performance of the DBR (diode bridge rectifier) circuit. As a end result, bridgeless PFC converters offer a better practical solution for enhancing electricity quality in EV chargers, with fewer component currents switching inside the cycle and decrease conduction losses. In this context, various unmarried-section unidirectional PQ-based totally increase converters were investigated, as they are able to step down and step up the enter voltage, at the same time as a bridge type dollar-raise converter may be the most attractive answer for PFC in EV fleets. Various types of RAM converters which includes BUCK and SEPIC converters had been identified and analysed.

Zeta, BUCK and SEPIC PFC converters have a extensive input modern-day command and obligation cycle variety, unlike the BUCK converter, which has a slim range. Due to the low ripple cutting-edge of the battery, the BUCK converter gives very good battery charging characteristics. Many BL BUCK converter topologies are based totally on the traditional PFC BUCK converter, which might be mentioned inside the literature [10-13]. All these topologies have boundaries in terms of computational complexity, losses, efficiency and interconnection necessities, with a purpose to be discussed within the subsequent segment. It offers blessings inclusive of low enter cutting-edge, reduced EMI and simplicity of use. However, because of the connection of two intermediate capacitors C1 and C2, it faces a modern trouble, which leads to extra losses on both facets of the deliver voltage. This device makes extensive use of output capacitors, which has the drawback of a floating terminal for the load between the 2 output capacitors. In addition, it has the downside of being neutrally floating, because the rods are organized independently of the suggest of the tension pressure. Since the internal diode of the passive switch S2 usually conducts present day at some stage in the nice 1/2-cycle of the input voltage, through Li2, the circuit usually suffers losses thru the internal diode of the passive transfer. Due to the partial present day flowing via it at some point of the second one half of of the cycle. The different BL BUCK converters in [11] and [13] have the equal blessings of low part rely and reduced semiconductor loading gadget because the traditional BUCK converter. It isn't feasible to attach input and output inductors with any of those converters.

Therefore, this work proposes a brand new energy excellent advanced, bridgeless (BL) BUCK converter for charging electric vehicles, according with the advocated SAE J1772 fashionable. Below are the main

capabilities proposed in the platform in an effort to assist to resolve the issues indexed above. Due to the implemented voltage, there's no go back present day through the inner diode inside the different half of the loafer rod cycle. As a end result, the switching losses are decreased to a minimum. The PFC converter controls the identical gate and circuit operation for each contemporary source. The small size of the inductors of the proposed BUCK converter allows the converter to function in DCM (discontinuous conduction mode), which reduces the price and length of the converter. In BL operation, the line voltages D_p and D_n are again to floor via the line diodes.

RELATED WORK

RadhaKushwaha et al. (2019) Current reputes of right-hand drive batteries, charging stations and plug-in infrastructure and popularity for electric powered and hybrid motors. External and on-board charging structures are divided into sorts, with unidirectional or bidirectional electricity flow. Using unidirectional charging reduces the quantity of system required and simplifies the interconnection problem. It is feasible to offer battery power to the grid via bidirectional charging. Due to weight, space and value constraints, most vessels limit their capability. To conquer those problems, they may be connected to an electrical coupling. With the supply of charging infrastructure, the need for strength garage on board ships and its charges have decreased. On-board markings must be made, which are conductive or inductive. The outer shell is less restrained in length and weight and may be made for better speeds. The power degrees taken into consideration are Level 1 (cozy), Level 2 (primary), and Level three (velocity). Future features such as motorway series are mentioned. Power capability, time and area, cost, equipment, and other issues for one-of-a-kind ranges of energy grid and infrastructure configurations are provided, in comparison, and evaluated. Industrial Electronics for Electric Transportation: Current Status and Future Challenges [1].

DJ discusses current research traits and future challenges in business electronics related to transportation electrification. Liang et al., (2018) proposed. Special attention is paid to electric and plug-in hybrid electric cars (EV/PHEV) and their key energy additives. This article addresses problems associated with electric vehicle power garage structures, electric powered vehicle charging, electricity electronics, and traction motor design within the automobile industry. The importance of equalizing the voltage of battery cells to growth their provider lifestyles, inclusive of series-related lithium-ion (Li-ion) batteries, is mentioned. A comprehensive precis of the class, criteria, and requirements for EV/PHEV battery packs is also furnished. The topologies of some AC-DC converter topologies for EVs/PHEVs, and one by one the DC/DC topologies, are mentioned. Finally, this article discusses numerous electrical device architectures and green bidirectional DC-DC converter topologies. New methods of modulating DC-to-AC inverters for electric motors also are mentioned. These numbers are described in terms of voltage, power, and load variety. Using unidirectional charging reduces the amount of gadget required and makes it simpler to solve connectivity issues. Bidirectional charging lets in the battery to be fed into the strength grid. Most tabletop chargers have potential limitations due to weight, space, and value [2].

Xuan Shi et al. (2017) proposed a front-give up AC-DC converter, that's a key factor of a plug-in hybrid electric automobile (PHEV) gadget that have to attain high efficiency and electricity density. This article offers a topology overview exploring topologies to be used in AC-DC converters for PHEVs. Topological studies specializes in non-stop increase converters with energy element correction that provide excessive efficiency, excessive strength element, excessive density, and occasional cost. The test outcomes for five prototype common converters with an AC input voltage of four hundred V DC are defined and interpreted. The effects display that the section-transferring PFC step-down converter with 1/2-bridge manage is nice perfect for residential Class I car strength materials in North America, wherein the common deliver is 120V and 1.44kVA or 1.92kVA. The bridge-interposed PFC enhance converter is a perfect topology candidate for Level II vehicle batteries with electricity degrees of three.3 kW, 5 kW, and 6.6 kW in North America and

Europe. Different ranges of energy and infrastructure configurations, strength requirements, time and area, fee, gadget, and different elements are supplied, compared, and evaluated [3].

PROPOSED SYSTEM

Due to the high ripple present day of the battery, the BUCK converter gives excellent battery charging features. Among the many BL BUCK converter topologies primarily based on the traditional PFC BUCK converter, the important functions of the proposed circuit board to overcome the above issues are summarized as follows. The medium capacitance in each component works independently; hence, cycling losses are eliminated and the plate efficiency is expanded. Due to the manage used, there's no reverse present day thru the lively diode rod within the second half of the cycle. Hence, losses during conduction are reduced. The manipulate of the PFC converter is simple because the same gate drive and nearly half-cycle control are used. The small size of the inductors of the proposed BUCK converter permits the converter to function in DCM (Discontinuous Conduction Mode), which reduces the price and length of the converter. The BL structure within the proposed converter reduces the shipping losses, which increases the plate performance. The BL structure within the proposed converter reduces the transport losses, which will increase the plate performance. The range of elements in the conversion cycle is decreased; therefore, the plate performance is accelerated by using the designed converter. Several EV topologies for unmarried stage PFC converters were posted inside the literature. Due to the low number of elements, the single disk proved to be effective for the degree. On the other hand, the presence of 100 Hz resonant components within the output present day calls for a very high DC coupling potential. The -level rectifier with PF is a extensively applicable answer within the electrical market for medium strength programs up to 1 kW.

Advantages:

- The effective enter voltage can be reduced or multiplied to store area in the battery.
- The voltage to be had to control the tool may be extended or decreased.
- The proposed PFC BUCK converter gives the quality PFC performance in DCM mode using unmarried-enter remarks control, which prevents system harm or failure. As a result, the plate size is decreased.
- Another gain of the proposed topology is that it gets rid of pointless capacitive coupling loops and useless delivery via the passive transition diodes as carried out in previous BL BUCK converters.
- The BL BUCK converter avoids passive switching of the inner diodes earlier than beginning. This appreciably improves the defensive overall performance.
- The proposed plate well-known shows excellent traits in steady state and at more than 50 percentage community voltage drop-blocking.
- No hassle with floating impartial conductor and reduced electromagnetic interference. The BL structure reduces the transmission loss of the converter, which improves the efficiency of the platter.
- The range of components to be changed in a cycle is decreased, ensuing in increased disk performance with the proposed converter.

BLOCK DIAGRAM

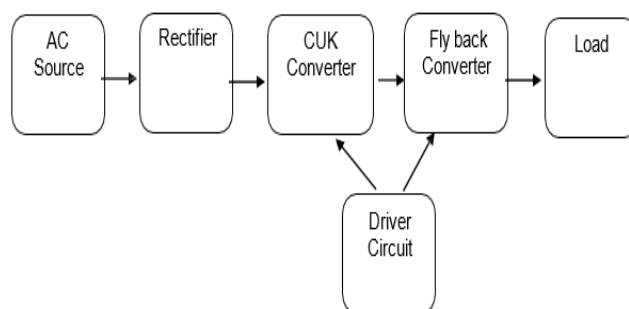

Fig 1: Block diagram of proposed system

A traditional EV charger that attracts most present day from the grid with a diode bridge rectifier (DBR), which reduces the enter electricity aspect (PF), total harmonic distortion (THD) by up to fifty five.3%. Several PFC enter converter topologies were discussed inside the EV charging literature, relying at the external or internal configuration. [6] Various battery packs have been described in the literature for electric powered cars, which have widespread advantages for excessive power density and efficiency. However, the outside configuration gives a extra green answer because of the reduced weight of the vehicle and the better electricity potential appropriate for loading. Various PFC converter topologies have been reported, consisting of enter-to-enter switching and zero voltage switching (ZVS) techniques. Switching the 2-section input offers the benefits of reducing output ripple present day and lowering inductor length. Furthermore, the semiconductor gadgets perform in parallel, which results in highly low conduction losses. However, in contrast to step-up PFC converters, step-down PFC converters do no longer offer a approach to the problem of poor thermal overall performance the usage of PFC rods. A resonant LLC converter is being taken into consideration for an electric automobile, which has the delivered advantage of low electromagnetic interference (EMI) and switching losses. But the complicated mathematical evaluation of a noisy converter makes it incorrect for powering electric powered motors over a extensive variety of enter voltages. A full-bridge PFC converter appears to be the maximum promising solution for eV shields, but designing separate gate drivers for the four semiconductor rods increases the size and complexity of the tool. Several EV topologies with a single PFC converter stage were pronounced in the literature. Due to the low wide variety of elements, the unmarried disk proved to be effective for the degree. On the other hand, the presence of a 100 Hz ripple inside the output present day requires a completely high DC hyperlink capacitance. The medium capacitance in every part works independently; therefore, biking losses are removed and the plate performance is extended. Due to the strength used, there is no go back current thru the energetic rod of the inner diode in the second 1/2 of the cycle. Therefore, losses throughout delivery are decreased. The manager of the PFC converter is simplified by means of the usage of a single gate driver and controlling it during every half-cycle of the cycle. The output inductors of the proposed BUCK converters are designed to be so small that, for the reason that converter operates in DCM (Discontinuous Conduction Mode), the cost and size of the converter are decreased. There is no floating neutral trouble and the electromagnetic noise interference is decreased. The delivery loss is decreased in the proposed converter because of the BL shape, which increases the plate efficiency. The number of elements is reduced in each switching cycle; consequently, the plate performance is accelerated as per the purpose of the converter. Since the PFC converter makes use of the same gate pressure and control circuit for each 1/2-cycle, the manipulate becomes clean. The output inductors of the proposed BUCK converter are small sufficient to permit the converter to function in Discontinuous Conduction Mode (DCM), which reduces the price and size of the converter. Current fame of battery packs, charging electricity ranges and plug-in infrastructure for electric and hybrid motors and their implementation. External and on-board charging systems are divided into kinds, with unidirectional or bidirectional electricity glide. Using unidirectional charging reduces the quantity of device required and simplifies the interconnection problem. It is viable to provide battery electricity to the grid via bidirectional charging. Due to weight, space and fee constraints, maximum EVs limit their skills. Several EV differential topologies for unmarried-stage PFC converters had been posted within the literature. Due to the low variety of parts, the unmarried disk proved to be effective for the platform. On the opposite hand, the presence of 100 Hz ripple inside the output current requires a very high DC link capacitance. A extensively used answer for medium-strength vehicles up to 1 kW inside the EV market is a dual-plate charger with a power thing corrector converter.

CIRCUIT DIAGRAM

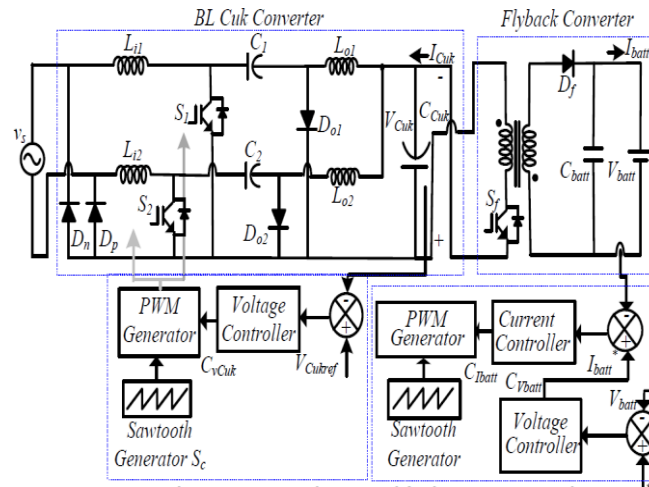

Fig 2: Circuit diagram of proposed circuit

MODES OF OPERATION

The structure and functionality of the suggested electric vehicle charging device with stepped forward electrical first-rate are shown in Figures 3 and 4. Li1-S1-Do1-Lo1-Dp and other converter movable BUCKs operate at some point during the pleasant half of the cycle. Li2-S2-Do2-Lo2-Dn, another component of the BUCK converter, remains active during the dreadful 1/2-cycle. The inductors Li1 and Li2 are set up to operate in CCM mode for both of the BUCK converter's cells. Nevertheless, the output inductors Lo1 and Lo2 are made in such a way that the converter remains in DCM mode after one diode switching cycle, at which point the output current i_D becomes 0. In order to maintain a constant voltage across all of the capacitances at some point during the switching time, the intermediate capacitances C1 and C2 were chosen. The output voltage of the PFC converter BUCK is maintained steady by every comments voltage-loop control [7-8] because the most efficient single voltage sensor is employed, which lowers the circuit cost. The unstable converter is set up to operate in DCM mode [9] in the CC (constant voltage) and CV charging zones, which regulates the battery rate using a cascaded PI controller.

Operation of BL BUCK PFC Converter

As demonstrated in Figure 2, the additive half-cycle of the BL converter is considered because of the waveforms' closeness. This section defines the BUCK converter's operating principles in order to illustrate how the suggested digital circuit operates. The unstable converter is configured to operate in DCM mode with a cascaded PI battery controller in the CC (constant voltage) and CV charging zones.

Mode P-I [switch ON period, $0 \leq t \leq D_{BUCK}T_s$]:

When the gate pulse is carried out to exchange S1 for time t_1 , the first superb half-cycle (PI) operating mode starts offevolved. With a voltage of $V_{spk}(t)/L_{i1}$, the modern-day through the inductor L_{i1} increases linearly. The current direction is $v_s-L_{i1}-S1-Dp-v_s$ since the diode D_p is in the high quality linear operating condition. The first switching waveforms with the three modes are shown in Figure 3.1. The voltage across the intermediate capacitor C1 starts to decrease through the output of the switch S1 and the inductor L_{o1} , providing the necessary load current for the floating converter. The output diode D_{o1} stays reverse biased throughout this period because of the polarity of the voltage across the intermediate capacitor C1. Therefore, $v_{spk} BUCK s s1pk eq V D T I L (1)$, where L_{eq} is the equal inductance of the conversion circuit, i.e., input inductor L_{i1} and output inductor L_{o1} , yields the maximum voltage at junction S1. T_s is the total switching time, D_{BUCK} is the interval between S1 durations, and V_{spk} is the highest cost of the input AC voltage.

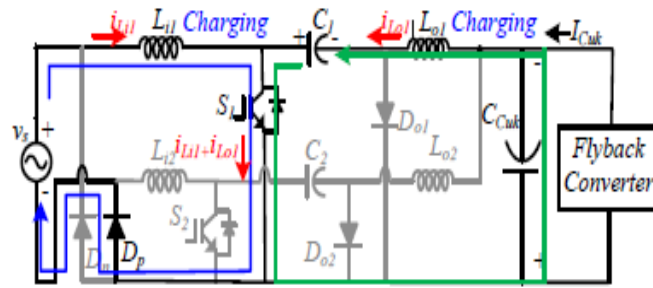

Fig 3: Circuit diagram for Mode P-I

Mode P-II [switch OFF period, $D \text{ BUCKTs} \leq t \leq D1Ts$]:

When switch S1 is activated at time T2, this mode is started. As illustrated in Figure 3, the output diode Do1 enters conduction and the voltage across the intermediate capacitor continues to expand and grow as input inductor Li1 starts to release the energy stored through C1 and Do1. 2. The inductor Lo1 provides the designated output load cutting-edge when the saved strength is released by the output diode Do1 and the DC capacitor CBUCK. Current flows through the output inductor i_{Lo1} in the equation $L_{o1} \text{ BUCK } o1 \text{ di } V \text{ dt } L$ (2), where V_{BUCK} is the BL BUCK converter's output voltage. The switching period ends at time t3 when the modern waft via the output diode drops to 0.

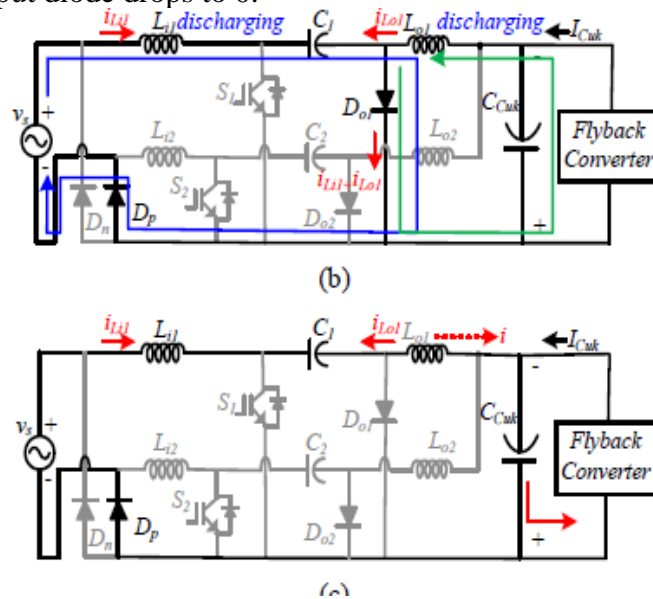

Fig 4: Circuit diagram for Mode P-II

Differential Aspect of Proposed PFC Converter

The following is a list of the many aspects of the PFC converter proposals in contrast to topology three and BL BUCK-1.

Since there is no link between C1 and C2, the cycling losses are eliminated, increasing the circuit is efficiency. In Figure 3, however, the capacitance of each component functions independently. Because the internal passive diode S2 is continuously operated through Li2 for the entire amazing half-cycle of the input voltage, as shown in Figure 3.3, topology-3 will become harmful. because of standard control. This indicates that not only does modern technology float through Dp during the first half of the operating cycle, but some of it also returns through the internal diode S2 and inductor Li2. Similarly, modern-day drift now occurs not just through the diode Do1, but also through the diode, the frame of Dp, and the inductor Li2, when transfer S1 is closed. For the duration of half-cycle operation, the same thing occurs with transfer S2. This happens because only one switching operation uses half of the PWM signal. This technique may

completely cut out the alternative half and flip the alternative on S1 or S2. Because of the partial opposing current flowing during the corresponding 1/2-cycle of operation, the circuit always experiences some loss through the inner diode of the inactive switch (S1 or S2).

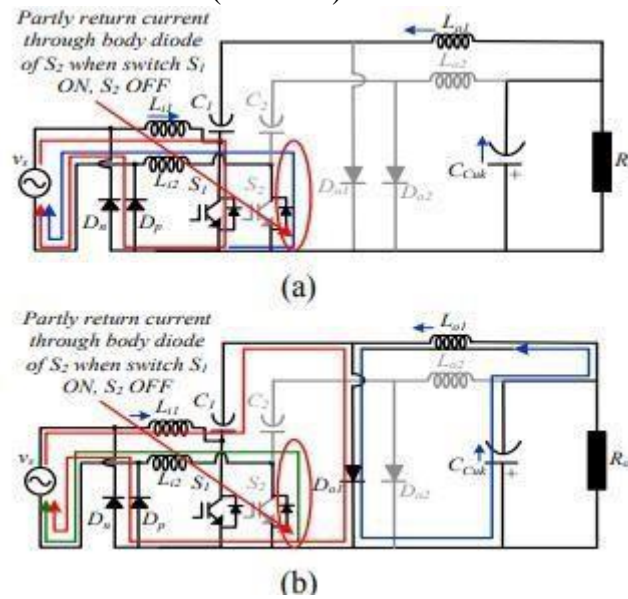

Fig 5: Differential Aspect of Proposed PFC Converter

There might not be a reverse cutting-edge across the inner diode of the inactive switches during the corresponding 1/2-cycle because of the applied voltage, as seen in Figure 3. Because the same gate driver and manage circuit are used in every cycle—that is, both switches S1 and S2 are driven by the equal sign simultaneously—managing the PFC converter is simple. In other words, the conduction loss through the frame of the passive diode switches can be decreased by electrifying the switches S1 and S2 using the equal driving force sign and the intermediate driving force sign. Consequently, there are fewer losses in the inner diodes. The actual operating methods can hardly be separated by the same driving force indication.

Operation of Flyback Converter

The implementation of the astable converter is developed based at the DCM high frequency magnetic induction converter (HFT). In mode I, the modern increases linearly thru the EMF of the inductor magnet and adds energy to the astable Sf whilst it's miles became on. Due to the HFT consensus point, the output diode Df is biased at this factor. The modern-day flows thru the transfer Sf.

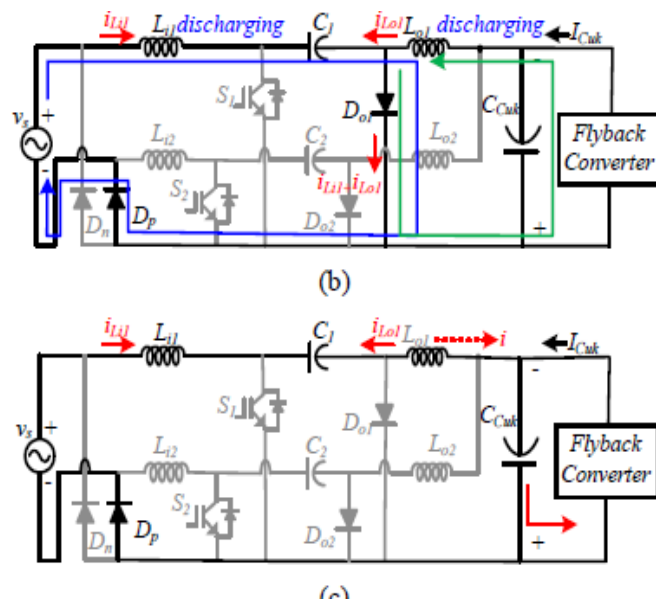

Fig 6: Operation of Fly back Converter

At time t_2 , mode II is initiated while the switch S_1 is closed. The battery output receives energy during the reverse because the HFT polarity is reversed and the output diode D_f is accessible. Both the switch conduction and the diode voltage V_{Df} are zero. Mode III, sometimes referred to as the remote conduction mode, begins to emerge when the transfer and the diode are both closed. The strength stored in the magnetic circuit is fully transferred to the output at the end of the switching cycle. Currently, the battery in CC mode receives the necessary cutting-edge from the output capacitor C_{cut} .

Control of Proposed EV Charger

The next subsections cover the control technique for the suggested charger.

Control of Bridgeless PFC Converter

With energy in voltage following mode, the suggested BL PFC converter is set up to operate in isolated conduction mode. A PI (Proportional Integral) controller controls the voltage follower, which modifies the community according to the input voltage. Even when the input voltage varies significantly, the BL converter's overall performance stays constant. The difference in voltage (V_{BUCK}) from an abrupt change within the straight modern-day voltage is found using a voltage sensor. The desired voltage ($V_{BUCKref}$) and the measured voltage are contrasted. The voltage comments controller receives the V_{BUCK} errors. By using an equal gate motive force and regulating it by a loop around the half-cycle, the suggested control scheme simplifies the PFC energy converter in an innovative way. With the same driver providing the signal, switches S_1 and S_2 operate in unison. To put it another way, Figure 6 illustrates how the same driving force signal is utilized to lower the conduction loss through the idle rods' inner diodes, which in turn lowers the internal losses of the idle diodes in the subsequent 1/2-cycle.

Control of Flyback Converter

A single-stage dual PI controller regulates the output of the hazardous converter in order to charge the CC battery under all operating conditions. This is accomplished by measuring the battery voltage V_{batt} and comparing it to a hard and fast voltage V_{batt}^* . The PI voltage regulator receives the V_{batt} voltage errors. The output loop of the external PI controller units the state-of-the-art I_{batt}^* as the contemporary for the inner loop as the output signal derived from the PI controller satisfies the most modern requirements. The inner PI cutting-edge regulator receives the inaccuracy when the measured modern I_{batt} of the electrical vehicle battery is compared to this reference cost. When the voltage PI regulator loop is not operating and

the voltage regulator output is saturated with the current reference value. By matching the output sign of the PI modern controller with a sawtooth wave, a PWM generating module is used to create the necessary pulses for battery mode in CC. Error Control Signal, iPad and Control Signal When the PI controller loses power, the manage circuit switches to CV mode while the battery reaches the precise SOC restrict (approximately 80%). Thus, the PI regulator maintains a regular voltage reference cost, and the battery is charged to the maximum voltage, that's equal to a hundred percentage SOC. This approach is called constant voltage mode due to the fact at the end of each cycle the battery is absolutely charged and the contemporary is drawn from the supply.

DESIGN OF PROPOSED PFC CONVERTER BASED CHARGER

The cost of EV discretization is directly associated with the need for PF correction sensors of the converter. The CCM control scheme uses the inner waveform function, and the modern-day amplifier approach to enforce DC hyperlink manipulate. Due to the need to degree both the enter voltage and output present day, a large number of sensors are required inside the CCM. The main benefit of CCM operation is the discount of load modern in the switching and PFC converter components.

The range of sensors required for DCM operation is decreased due to the fact the manipulate circuit is based on the voltage follower approach and the best measured value is the converter output voltage.

Design of Proposed Circuit

1	Input inductor	3.86mH	4mH	CCM
2	Output inductor	0.222mH	0.15mH	DCM
3	Intermediate Capacitor	2.712 μ F	3 μ F	CCM
4	DC link Capacitor	3mF	4.7mF	-
5	HFT Magnetizing Inductance	164.37 μ H	30 μ H	DCM
6	Output Capacitor	1.585mF	2mF	-

Proposed Circuit Values

S. No	Components	Specifications
1	Input Inductance, $l_{i1,2}$	4mH
2	Output Inductance, $l_{o1,2}$	150 μ H
3	Magnetizing Capacitor $C_{1,2}$	3 μ F
4	Magnetizing Inductor, L_f	130 μ H
5	Transformer Turns Ratio	0.333
6	Battery Specifications	48V,100Ah
7	DC-link Capacitor C_{cuk}	2000,400V
8	Output Capacitor	2000,100V

Table 1 lists the proposed circuit's designed values, while Table 2 lists the component specifications.

HARDWARE DESCRIPTION

DC TO DC CONVERTER

DC to DC converters are required for small automotive digital gadgets such as cellular telephones and laptops. Many such digital gadgets also have auxiliary circuits, every of which requires a extraordinary voltage degree than the battery (every now and then better or lower than the battery voltage and might even be a poor voltage). In addition, as the battery's saved power decreases, the battery voltage decreases. Instead of the usage of multiple batteries to power exclusive components of the device, DC/DC converters permit more than one regulated voltages to be generated from a single AC battery voltage, thereby saving energy.

ON STATE

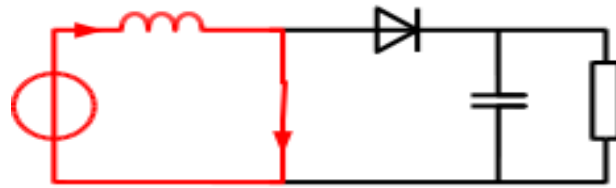

OFF STATE

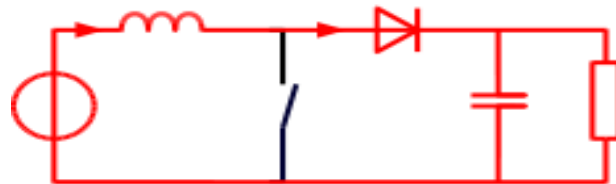

FIG 7:Operationalstates ofDC-DC Circuit

BUCK CONVERTER

Step-up and step-down converters use an inductor to transfer energy among the input and output; this analysis is based totally on the voltage balance throughout the inductor. The BUCK converter uses capacitive strength switch and its analysis depends at the modern-day capability.

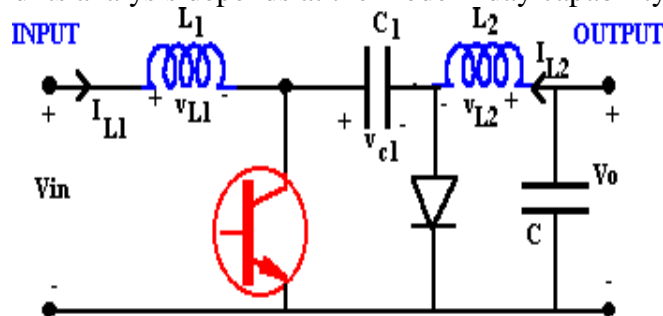

Fig 8: Derived from DUALITY principle on the buck-boost converter

Therefore, the voltage ratio of the step-down converter can be the equal. The BUCK converter has the benefit of producing DC contemporary on both aspects of the converter, even as buck, improve, and step-down converters have pulsating present day on as a minimum one side.

TRANSFORMER

A transformer is a type of passive electrical device that transfers electric electricity from one circuit to some other thru electromagnetic induction. It is crucial to growth or lower the voltage stage between groups.

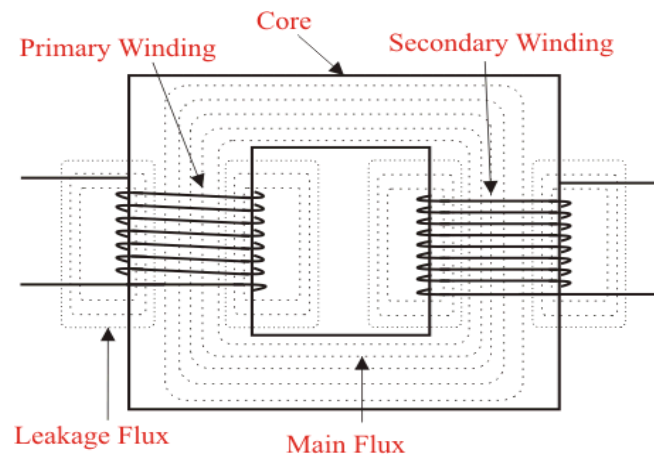

Fig 9: Working principle of a transformer

The feature of the transformer centre is to offer a course of least resistance thru which the maximum amount of primary winding modern can pass and connect to the secondary winding. The inrush modern-day of a transformer is the modern that flows thru it while it is first became on.

FLYBACK CONVERTER

A fly back converter is a electricity supply topology that uses an interconnected inductor to save energy when contemporary flows through it and launch it with faraway control. In phrases of design and performance, fly back converters are much like enhance converters. On the other hand, the primary winding of the transformer acts as an inductor, and gives a secondary output. The primary and secondary windings are separate inductors in a floating configuration. They are used.

ARDUINO UNO

With Arduino's help, the Microchip ATmega328P microprocessor evolved. Shields and other circuits can be attached to the board's digital and analog enter/output (I/O) pins. The board features six digital I/O pins (six of which are PWM outputs), six analog I/O pins, and can be programmed using the Arduino IDE (Integrated Development Environment) via a USB Type B connector. [Numeral four] Either an external 9-volt battery with a voltage range of seven to twenty volts or a USB cable can power it. It resembles the Leonardo and Arduino Nano microcontrollers. The Arduino website makes the hardware reference design available under a Creative Commons Attribution Share-Alike 2.5 license. The word "Uno" means "one" in Italian, and it was chosen to symbolize the initial release of the Arduino software. Together with the Arduino IDE's 1.0 version, the Uno board was the mainstay of a line of Arduino boards that were primarily focused on USB. It also functioned as the reference model for Arduino in later iterations. With the bootloader pre-programmed within the ATmega328 board, you can write fresh code without the need for external hardware programming. Unlike all previous boards, the Uno does not employ the FTDI USB-to-serial chip driving force, despite using the genuine STK500 protocol.

DRIVER CIRCUIT

A wellknown digital good judgment output pin can handiest supply tens of milliamps of cutting-edge. Small external gadgets inclusive of excessive-energy LEDs, motors, audio system, light bulbs, buzzers, solenoids, and gadgets require hundreds of milliamps, despite the fact that they require the identical voltage degree. Larger devices can be required for better amps. To drive small DC devices at the specified power level, while the voltage and present day degrees are within appropriate limits, the transistor acts as a excessive-modern-day transfer controlled directly by using a virtual logic sign. In older or low-voltage circuits, a discrete BJT is regularly used in preference to the newer MOSFET, as proven under. Any GPIO pin on the board may be used as a common sense control input for a virtual output circuit. As an opportunity to

discrete transistors, devoted driver ICs are now available which could pressure many gadgets. These ICs have inner transistor force circuitry as mentioned above. The ULN2803 500mA 50V eight-channel motive force proven underneath is still available in a die-cast bundle that may be plugged into a breadboard, however the contemporary is a floor mount IC that calls for a fan out board (10) for use on a breadboard.

MATLAB

MATLAB is a software package for computer simulation in engineering, science, and applied mathematics. Simulink (Simulation and Linkage) — is an extension of MATLAB from MathWorks Inc. It, collectively with MATLAB, affords a graphical person interface (GUI) for modelling, simulating, and reading dynamic structures. Model creation is simple with click-and-drag operations. Simulink comes with a massive library of gear for linear and nonlinear evaluation. These fashions are hierarchical, taking into account each pinnacle-down and bottom-up approaches. Since Simulink is a part of MATLAB, it is easy to exchange among the 2 during evaluation, permitting customers to completely utilize the capability of both environments. This educational focuses on the concept of logic and introduces the simple capabilities of Simulink. It is written for students in my Control Systems. Electric electricity structures are composed of circuits and electromechanical devices together with cars and turbines. Engineers on this subject are continuously running to make certain that the structures are operational. To meet the requirements, electricity machine designers are compelled to apply digital power systems and advanced system principles to test conventional dimension methods and techniques. The position of the analyst turns into even greater complex due to the fact those structures are regularly nonlinear, and the simplest way to recognize them is through a model.

SIMULATIONRESULT

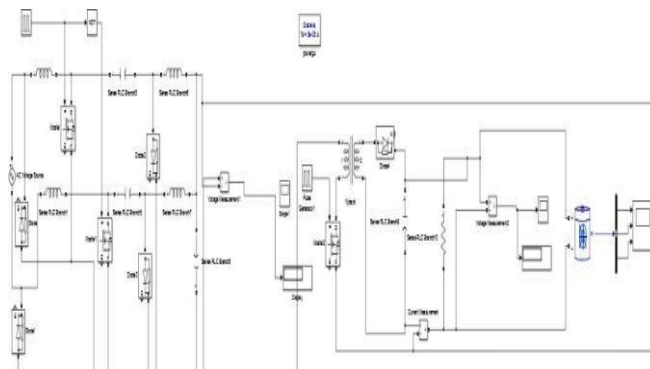

Fig 10: Open loop simulation

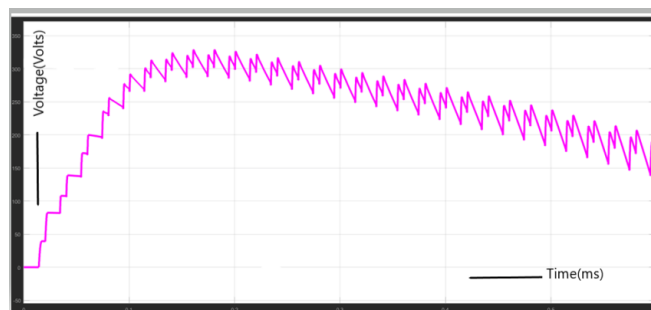

Fig 11:Output of the voltage BUCK converter

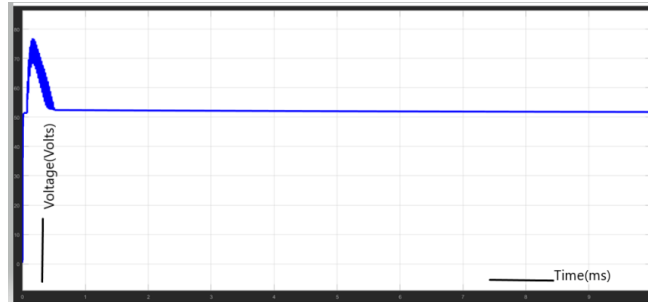

Fig 12:Output of the voltage Fly back Converter.

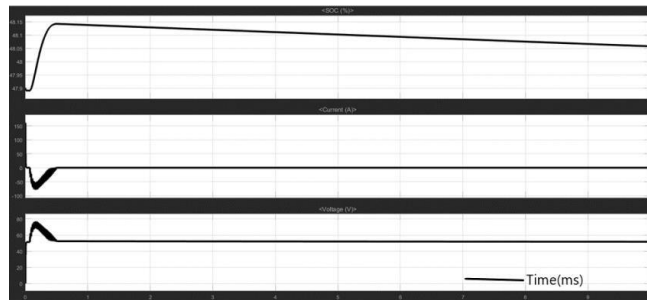

Fig 13: State of charging (soc)

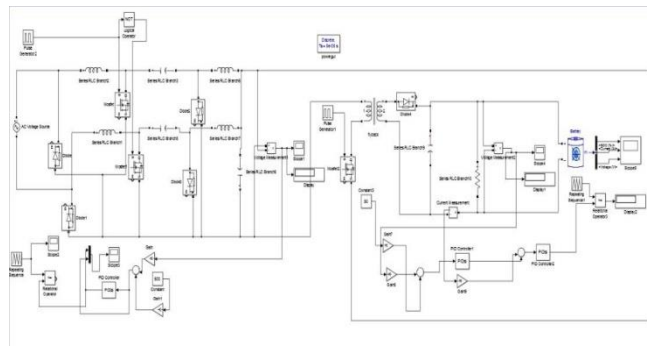

Fig 14:Closed loop simulation

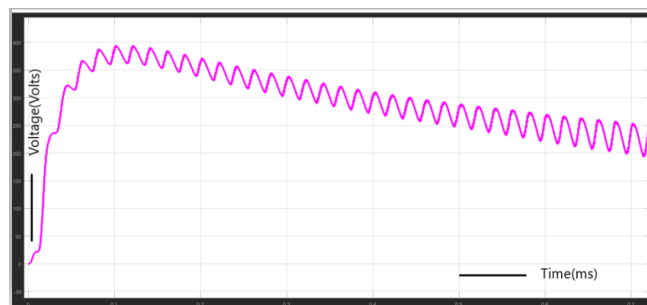

Fig 15:Output of the voltage BUCK converter

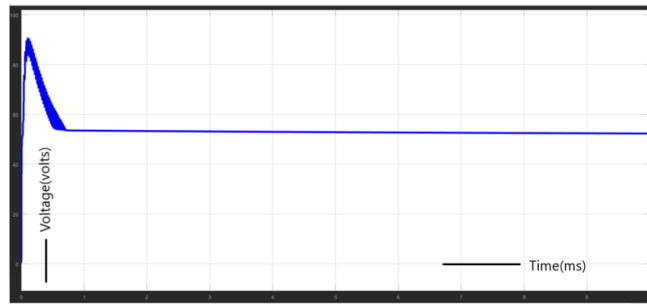

Fig 16: Output of the voltage Fly back Converter



Fig 17: State of charging (soc)

CONCLUSION

An progressed PQ-primarily based drive is offered in an electric car, which has a BL BUCK converter and less conductive factors for switching instances. The proposed BUCK PFC converter achieves the first-class PFC overall performance in DCM mode via unmarried-ended voltage remarks. As a end result, the plate size is decreased. The proposed topology eliminates pointless capacitive coupling loops and useless delivery via internal passive diode switches within the formerly evolved BL BUCK converter. This substantially improves the shielding overall performance. In constant kingdom and with network voltage deviations of greater than 50%, the charger indicates first-rate overall performance for its intended motive. However, the proposed PQ partition is calculated the usage of the functions for a wide variety of enter voltages. As a end result, the proposed invoice gives a viable option for charging electric powered cars with stepped forward electricity exceptional and efficiency.

REFERENCES:

- [1] Bhim Singh, Brij N. Singh , Ambarish Chandra , Kamal A1-Haddad , Ashish Pandey , and Dwarka P. Kothari , “A review of single – phase improved power Quality AC-DC converters,” IEEE Transactions Industrial Electronics , Vol.50, No, pp. 962-981, July 2003.
- [2] Chan C and Chau K ,”Power electronics challenges electric vehicles,” in Proc. IEEE IECON’ 93 . ,pp. 701-706 .
- [3] Choin H, “ Interleaved Boundary Conduction Mode (BCM) Buck Power Factor Correction (PFC) Converter,” IEEE Transactions Power Electronics, Vol. 28, no. 6 pp. 2629-2634, June 2013 .
- [4] Chaun Shi, Yichao Tang and AlirezaKhaligh, “ a single – phase integrated on board battery charger using propulsion Transactions system for plug – in electric vehicles,,”IEEE Trans Veh. Technol. , vol . 66, pp. 10899-10910, Dec . 2017.
- [5] Jovanovic M M and Jang and Lee B K , “ An integrated battery charger with high Power density and efficiency for Electric vehicles,,” IEEE Trans. Power Electron . , vol.32, no. 3, pp. 701-708,, June 2017.
- [6] Kim D H, Kin M J and Lee B K , “ An integrated battery charger with high power density and efficiency for electric vehicles ,” IEEE Trans . Power Electron . , vol. 32 no. 6, pp. 4553-4565 , June 2017 .

- [7] Kushwaha R and Singh B , “An Improved EV Charger For Electric Vehicles with High Power Factor, ‘in Proc. IEEE IAS Annual Meeting , 2018, pp. 1-8.
- [8] Li C and Xu D , “Family of Enhanced ZCS Single-Stage Single- Phase Isolated AC-DC Converter for High –Power High- Voltage DC Supply, “ IEEE Trans . IndElectron . , vol. 64 no. 5, pp. 3629-3639, May 2017.
- [9] Lee S ,Cha W and Kwon B , : High –Efficiency Soft-Switching AC-DC Converter With Single-Power-Conversion Method, “ IEEE Transactions Industrial Electronics , vol. 64 , no. 6, pp.4483-4490, June 2017.
- [10] Musavi F ,Edington M , Eberle Wand Dunford W G , “ Evaluation and Efficiency Comparison of Front End AC-DC Plug- In Hybrid Charger Topologies ,” IEEE Transactions Smart Grid , vol. 3, no. 1, pp. 413-421 , March 2012.
- [11] Peterson L and M. Anderson. “ Two – Stage power factor corrected power supplies The Low Component – stress approach, “ In Proc . IEEE APEC, 2012, vol. 2, pp. 1195-1201.
- [12] Tar B and A. Fayed , “ An overview of the fundamentals of battery chargers , “ IEEE MWSCAS’ 16 , pp. 1-4.
- [13] Williamson S S ,Rathore A K , and Musvi F, “Industrial electronics for electric transportation: Current state-of-the-art and future challenges ,” IEEE Transactions Industrial Electronics, vol. 62, no. 5, pp.. 3021-3032. May 2015.
- [14] Yilmaz M and Krein P T ,” Review of battery charger topologies, charging power levels and infrastructure for plug-in electric and hybrid vehicles, “ IEEE Transactions Power Electronics . vol. 28, no. 5 ,pp. 2151-2169, May 2013