

# Design and Implementation of a Microcontroller-Based Temperature Control and Monitoring System for Refrigerated Trucks

Samiksha Shailesh Nalawade<sup>1</sup>, Dhanshree Biradar<sup>2</sup>,  
Rajlakshmi Nilesh Desai<sup>3</sup>, Manas Girish Kulkarni<sup>4</sup>,  
Dr. Pravin G. Gawande<sup>5</sup>

<sup>1,2,3,4</sup>Student, Dept. of Electronics and Telecommunication Engineering, Vishwakarma Institute of Information Technology, Pune, India.

<sup>5</sup>Professor, Dept. of Electronics and Telecommunication Engineering, Vishwakarma Institute of Information Technology, Pune, India.

## Abstract

The transportation of pharmaceuticals and perishables through the cold chain requires strict temperature control. This paper presents a compact and affordable overheat detection and control system using the ATmega328 microcontroller. The system tracks the internal temperature through the LM35 sensor while showing readings on an OLED display and triggering a buzzer when temperatures reach 10°C. The Peltier module functions as a cooling mechanism to bring the chamber temperature back within its desired range. The system provides an excellent solution for small refrigerated trucks and containers in mobile medical and food logistics operations because it offers portability, real-time feedback, and autonomous operation.

**Keywords:** ATmega328, LM35, Peltier Module, OLED Display, Overheat Detection, Cold Chain Monitoring, Embedded Systems, L293D Motor Driver, Buzzer Alarm

## 1. Introduction

The transportation of healthcare and food products requires precise temperature control as a fundamental requirement. The current traditional systems are either too bulky, expensive, or require manual monitoring. The proposed project introduces an affordable embedded system that provides automated thermal control using minimal hardware. The system monitors the environment inside a refrigerated vehicle using an LM35 sensor. The OLED display shows current temperature readings, and the buzzer alerts when the system detects excessive heat. The Peltier TEC1-12706 module activates to lower the temperature when it exceeds the 10°C threshold.

## 2. Literature Review

Recent advancements in microcontroller-based temperature monitoring systems play a crucial role in enhancing the efficiency and reliability of both cold chain logistics and industrial applications. Multiple research studies have investigated how sensors along with controllers and wireless communication systems function for real-time monitoring and control.

The ATmega microcontroller system presented by Ghosh and Sinha [1] used the LM35 sensor to establish real-time temperature monitoring. The study focused on budget-friendly implementation with reliable accuracy which makes it ideal for small temperature-sensitive settings. Khan and Aibinu [2] created a monitoring system which used a microcontroller for alert functionality to prove its effectiveness in low-cost systems requiring immediate updates.

Fahim et al. [3] and Gupta and Kumar [4] studied IoT-based systems for monitoring both temperature and humidity levels in cold storage environments. The integration of cloud services enabled remote surveillance and historical data logging which improved traceability within cold chains as shown by these studies. Patel et al. [5] further expanded this research by adding intelligent decision-making components that enable automatic control responses when environmental conditions change.

Sarkar and Ashrafi [6] introduced an innovative approach to data compression through machine learning by developing a genetic sequence compression method that shows potential for sensor data storage and transmission efficiency. Such methods show potential to enhance storage optimization in embedded monitoring systems although they do not directly relate to temperature systems.

Shohet [7] gave an extensive analysis of energy-efficient cooling technologies through his discussion of refrigerated transport systems and system-level design for improved energy efficiency. TEC Microsystems [8] and Analog Devices [9] provided fundamental technical information and operational guidelines about Peltier module implementation for active thermoelectric cooling in microcontroller-based systems.

Mazidi et al. [10] presented essential information about microcontroller programming and interfacing which serves as a fundamental requirement for implementing all the discussed systems. Embedded systems education and practical design continue to rely on this text as their fundamental foundation. These research findings demonstrate how temperature control systems evolve toward intelligent and networked energy-aware systems. Future research in this field will likely produce adaptive and efficient thermal management solutions for industrial and commercial applications.

### 3. Objective

To design and implement an overheat detection system using an ATmega328 microcontroller, LM35 temperature sensor, and a Peltier cooling module that monitors and maintains the internal temperature inside a refrigerated truck below 10°C.

### 4. System Overview

The major functions of the system are described below, which work together to achieve effective temperature regulation and autonomous operation.

**Temperature Monitoring:** The LM35 analog temperature sensor operates continuously to monitor ambient temperature inside the refrigerated compartment. The output voltage corresponds directly to temperature measurements at a 10 mV/°C rate, which provides precise sensing.

**Data Processing:** The ATmega328 microcontroller uses its 10-bit ADC channel to read analog voltage signals from the LM35 sensor. The system transforms the data obtained into temperature readings before performing control logic operations to decide whether to activate the cooling and alert signals.

**Display:** The real-time temperature display function of this system uses an I2C-based OLED display module. The device operates at low power levels while maintaining a compact design, which makes it suitable for embedded systems that require basic user interfaces.

**Alert:** A buzzer is used to signal an audio warning when the sensed temperature exceeds a defined threshold of 10°C. This ensures timely intervention or inspection by the operator/driver.

**Cooling Mechanism:** The system activates the TEC1-12706 Peltier module when it detects overheating conditions. The system draws heat from the cold side (internal compartment) and releases it through its hot side, which is connected to a heatsink and cooled using an external fan. A fan is also used inside the chamber for internal air circulation.

**Control Interface:** The L293D motor-driver IC operates the two 12V fans, ensuring continuous heat dissipation.

#### 4.1 System Flow Diagram

**Figure 1. System Flow Diagram illustrating signal flow from temperature sensing to alert and cooling control.**

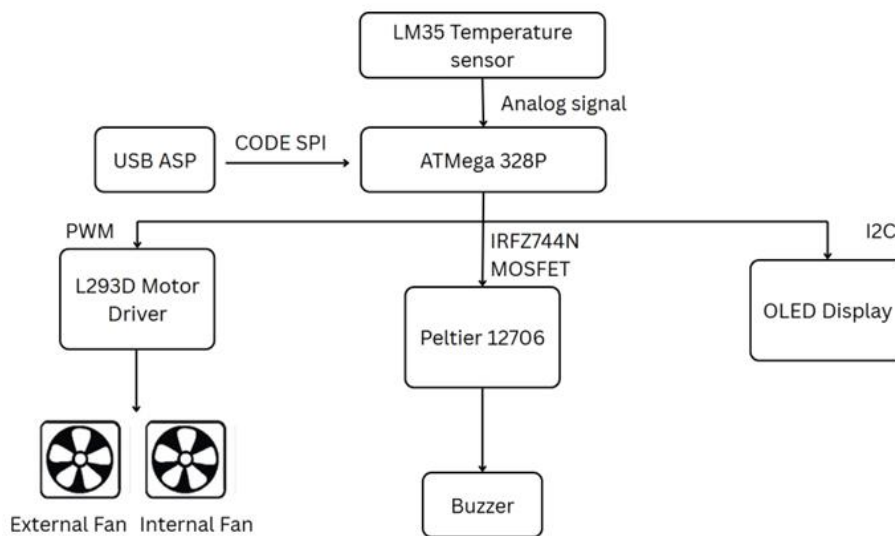

The flow diagram in [Figure 1](#) shows the logical sequence from temperature detection, analog to digital conversion, decision making by the microcontroller, the subsequent action to activate the buzzer, and to start the cooling process through the Peltier module and fans.

### 5. Methodology

The system operates through multiple essential subsystems that collaborate to detect overheating and alert, and mitigate overheating within the refrigerated truck cargo area.

#### 5.1 Temperature Sensing

The LM35 analog temperature sensor functions as the fundamental component of the sensing unit because it provides a linear output of 10mV/°C. The linear output makes calibration simple and enables direct communication between components. The sensor resides inside the cargo space where it connects directly to an analog input pin of the ATmega328 microcontroller. The LM35 sensor operates from a 5V power supply, which keeps its output values within the ADC’s 0–5V readable voltage range for accurate measurement.

#### 5.2 Microcontroller Processing

The ATmega328 microcontroller reads voltage from the LM35 through its 10-bit ADC (Analog-to-Digital Converter). The microcontroller uses this raw data to calculate the actual temperature through a mathematical conversion formula. A predefined threshold is set at 10°C. When the sensed temperature surpasses this value, the microcontroller starts a sequence of events that includes activating the cooling



, providing insight into the hardware design and component placement.

*Figure. 3 PCB views*

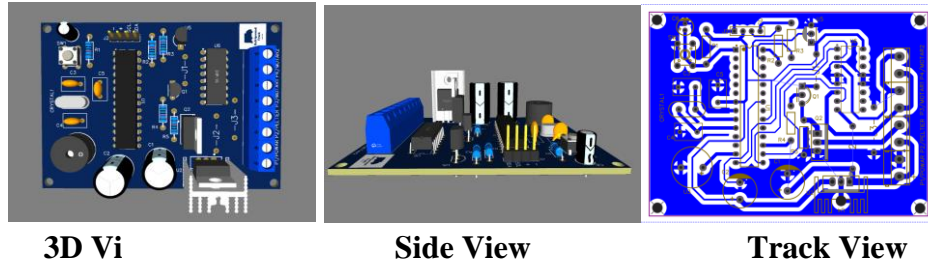

## 7. Equations

### 7.1 ADC to Temperature Conversion

$$ADC = (V_{in}/5) \times 1024 \quad (1)$$

$$Temperature (^{\circ}C) = \left(ADC \times \frac{5.0}{1024}\right) \times 100 \quad (2)$$

### 7.2 Peltier Control Logic

- If  $T > 10^{\circ}C \Rightarrow$  Turn ON Peltier and Fan
- If  $T \leq 10^{\circ}C \Rightarrow$  Turn OFF Peltier and Fan

## 8. Results

The overheat detection and cooling system was tested under controlled conditions, and it consistently performed as expected. Key results are summarized below:

**Temperature Sensing:** The LM35 sensor provided precise and stable real-time readings because it operates with a linear  $10mV/^{\circ}C$  response.

**Quick Detection:** The system detected the temperature exceeding  $10^{\circ}C$  with reliable results and responded within 1–2 seconds.

**Alert System:** A loud buzzer was activated instantly, ensuring attention in moderately noisy settings.

**Efficient Cooling:** The Peltier module and dual fans rapidly brought the temperature back below the threshold.

**Fan Control:** The L293D driver effectively controlled fan operation and helped dissipate excess heat.

**Display Feedback:** The OLED display showed real-time temperature values clearly under various lighting conditions.

**Power Efficiency:** The setup ran smoothly on a 12V supply, making it suitable for battery or solar power.

**Autonomous Functioning:** The system started functioning automatically after being activated, without requiring any manual intervention.

## 9. Hardware Output

The hardware implementation of the system inside and outside the truck is shown in Figure 4. The OLED showed real-time temperature readings during testing. The buzzer started, and the cooling module began operation when the temperature reached  $10^{\circ}C$ . The OLED display showed system status changes through visual output by displaying the fan speed, Peltier duty cycle, and live temperature. The fan rotation, together with the buzzer sound, verified that the hardware functioned correctly and the system operated automatically.

**Figure 4. Hardware setup inside and outside the truck chamber**

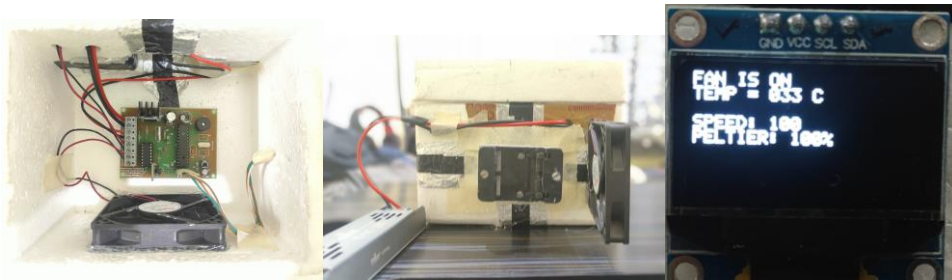

The entire system demonstrated suitable functionality for cold chain logistics applications, including vaccine transportation, dairy distribution, and mobile medical services.

## 10. Applications

The system performed as intended, with its fast operation, reliable functionality, and practicality for real-world cold chain applications. The system provides exceptional value through its automatic overheating detection, cooling activation, and clear alerts, making it especially valuable for:

**Vaccine Transportation:** The challenge of maintaining life-saving vaccines within the safe temperature range exists particularly during transit to remote or rural areas where power and monitoring resources are limited.

**Dairy and Perishable Goods Logistics:** Maintaining freshness and preventing spoilage of milk, cheese, and other temperature-sensitive food items during long-distance transportation.

**Mobile Medical Units:** Supporting field hospitals and emergency medical vans that carry temperature-sensitive medicines, diagnostic kits, and blood samples.

**Cold Storage in Remote Areas:** Acting as a compact and independent backup solution for cold storage in regions that lack reliable electricity or personnel for manual monitoring.

**Research Fieldwork and Expeditions:** Protecting biological or chemical samples collected during scientific research in extreme environments (like deserts or mountains) where temperature control is crucial.

**Consumer and Retail Use:** Integrating into portable coolers or smart fridges that vendors or delivery partners use to maintain quality and comply with storage standards.

The applications demonstrate the system's flexibility and scalability, which makes it appropriate for industrial applications as well as public health and field-based applications where reliability and autonomy are important.

## 11. Conclusion

This paper presents the design and implementation of an economical, microcontroller-based overheat detection and control system tailored for refrigerated transport vehicles. The ATmega328 microcontroller works together with the LM35 temperature sensor to provide precise real-time monitoring of the internal environment. The OLED display provides user-friendly feedback, while the buzzer alarm adds an immediate alert system in case of temperature breaches. The TEC1-12706 Peltier module works with L293D driver-controlled fans to provide automated, efficient cooling while ensuring proper heat dissipation.

Overall, this project demonstrates how embedded systems can provide smart, autonomous solutions to real-world problems like the spoilage of temperature-sensitive goods, thus enhancing public health, food safety, and logistics efficiency.

## 12. Future Scope

The current prototype provides a solid base for automated temperature control in cold chain logistics, yet there exists substantial potential for additional development. Future improvements could be made by adding GSM or IoT-based modules for remote monitoring and mobile device-based real-time alerts. Incorporating a rechargeable battery backup or solar-powered system would enable uninterrupted operation in off-grid or low-power areas. Advanced data logging features can be added to store the temperature history for quality assurance and compliance tracking. Additionally, machine learning algorithms could be integrated to forecast temperature anomalies and optimize cooling cycles through usage pattern analysis. The system can also be enhanced by adding a compressor to support more demanding cooling requirements. These upgrades would enhance the system's adaptability, efficiency, and value in various industrial and healthcare applications.

## References

1. S. Ghosh and P. Sinha, "Real-Time Temperature Monitoring System Based on LM35 Sensor and ATmega Microcontroller," *International Journal of Innovative Research in Computer and Communication Engineering*, vol. 4, no. 7, pp. 12 328–12 333, 2016.
2. Z. H. Khan and A. M. Aibinu, "Low Cost Temperature Monitoring and Alert System Using Microcontroller," *International Journal of Computer Applications*, vol. 87, no. 3, pp. 1–5, 2014.
3. M. T. Fahim et al., "Design and implementation of an iot based temperature and humidity monitoring system," in *2021 IEEE Region 10 Symposium (TENSymp)*, 2021, pp. 1–5.
4. P. Gupta and R. Kumar, "Design of iot based cold storage monitoring system," in *2020 International Conference on Smart Technologies in Computing, Electrical and Electronics (ICSTCEE)*, 2020, pp. 87–91.
5. K. Patel, V. Dodia, and S. Modh, "Intelligent cold chain management using iot for perishable products," in *2020 International Conference on Smart Electronics and Communication (ICOSEC)*, 2020, pp. 508–512.
6. M. H. Sarkar and A. F. Ashrafi, "Genetic Sequence Compression Using Machine Learning and Arithmetic Encoding Decoding Techniques," in *Proc. Int. Conf. Intelligent Systems and Control (ISCO)*, 2022, pp. 935–940.
7. J. L. Shohet, "Refrigerated Transport Technologies and Energy Efficient Cooling Systems," *IEEE Trans. Industry Applications*, vol. 50, no. 3, pp. 2307–2313, 2014.
8. TEC Microsystems, *Peltier Module Operating Guidelines*, 2020.
9. Analog Devices, "Using Thermoelectric Coolers in Temperature Control Applications," <https://www.analog.com/en/technical-articles/using-thermoelectric-coolers-in-temperature-control-applications.html>.
10. M. A. Mazidi, R. D. McKinlay, and J. G. Mazidi, *The 8051 Microcontroller and Embedded Systems Using Assembly and C*, 2nd ed. Pearson Education, 2006.
11. Microchip Technology Inc., *ATmega328 Datasheet*, 2023.
12. Texas Instruments, *LM35 Precision Centigrade Temperature Sensors*, 2021.

13. Atmel Corporation, ATmega328P: 8-bit AVR Microcontroller with 32KB Flash, 2016 [https://ww1.microchip.com/downloads/en/DeviceDoc/Atmel-7810-Automotive\\_Microcontrollers-ATmega328P\\_Datasheet.pdf](https://ww1.microchip.com/downloads/en/DeviceDoc/Atmel-7810-Automotive_Microcontrollers-ATmega328P_Datasheet.pdf).
14. Texas Instruments, LM35 Precision Centigrade Temperature Sensors, 2021, <https://www.ti.com/lit/ds/symlink/lm35.pdf>.
15. M. Alioto, "Energy-Quality Scalable Digital Design for Green Computing," IEEE Design & Test of Computers, vol. 29, no. 4, pp. 76–85, 2012.
16. M. Ali and A. Hassan, "Smart monitoring system for cold storage using microcontroller and gsm module," International Journal of Computer Applications, vol. 182, no. 47, pp. 25–29, 2019.
17. S. Sharma and R. Kumar, "Low-cost embedded temperature monitoring system for vaccine storage," International Journal of Electronics and Communication Engineering & Technology (IJECET), vol. 8, no. 1, pp. 24–30, 2017.
18. C. Chen and R. S. H. Istepanian, "A wireless monitoring system for coldchain logistics," in 2017 IEEE International Conference on Industrial Technology (ICIT), 2017, pp. 1069–1073.
19. S. Abid et al., "Design and implementation of smart temperature and humidity monitoring system for cold storage using gsm and arduino," Journal of Ambient Intelligence and Humanized Computing, vol. 12, no. 5, pp. 5379–5387, 2021.
20. A. L. Amoo, H. A. Guda, H. A. Sambo, and T. L. G. Soh, "Design and implementation of a room temperature control system: Microcontroller-based," in IEEE Xplore, 2014, <https://ieeexplore.ieee.org/document/7072989>.
21. V. Divakar, "Design and implementation of microcontroller based temperature data logging system," 2013.
22. D. Ibrahim, Microcontroller-based temperature monitoring and control. Oxford: Newnes, 2002.
23. "Cooling system temperature control using pic microcontroller," International Journal of Science and Research (IJSR), vol. 5, no. 5, pp. 2157–2160, 2016.
24. T. Wellem and B. Setiawan, "A microcontroller-based room temperature monitoring system," International Journal of Computer Applications, vol. 53, no. 1, pp. 7–10, 2012.
25. I. Riadi and R. Syaefudin, "Monitoring and control food temperature and humidity using internet of things based-on microcontroller," Jurnal Ilmiah Teknik Elektro Komputer dan Informatika, vol. 7, no. 1, p. 108, 2021.
26. B. I. Gunawan and U. Y. Oktiawati, "Server room temperature and monitoring system using fuzzy based on robotdyn microcontroller," Jurnal RESTI, vol. 4, no. 1, pp. 1–9, 2020.
27. C. C. Myint, "Microcontroller-based temperature and ph measuring system," International Journal of Trend in Scientific Research and Development, vol. 2, no. 5, pp. 694–698, 2018.
28. K. P. Dutta, P. Rai, and R. K. Pandey, "Microcontroller based automatic multichannel temperature monitoring system," International Journal of Advanced Research in Electrical, Electronics and Instrumentation Engineering, vol. 3, no. 9, pp. 11 771–11 777, 2014.
29. M. R. Amin, A. Ghosh, and A. Hadi, "Design and implementation of microcontroller based programmable smart industrial temperature control system: An undergraduate level approach," International Journal of Control and Automation, vol. 11, no. 4, pp. 117–124, 2018.